

## SlimFit Split Frame Clamshells



KRAIS SFSF portable SLIM FIT Clamshell series are designed for strength and easy handling. Each of the machine from the SFSF series have a height of 3,248" (82,5 mm) up 24" and 4,47" (113,7 mm) up to 48" and a width of 2.5" (63,5 mm) resulting narrow body low profile design that makes the SFSF series the ideal choice in tight spaces .

- 】 15 Standard models cover a range from 1." (33,4 mm) to 48" (1219 mm) OD
- 】 Pneumatic, hydraulic and electric drive options are available .
- 】 Motor mount on keyways to prevent the motor to twist and potential damage on gear ring .
- 】 Several different drive options are available to best position the motor for a specific machining application
- 】 All pneumatic and electric motors are design and Manufactured by KRAIS after 20 years experience of manufacturing pneumatic drives for boiler and heat exchangers tube rolling motors.
- 】 SFSF series clamshells can be equipped a wide range of accessories to increase performance and expand capabilities.
- 】 Adjustable locator pads minimize the number of locators.



### FEATURES



Choice of 3 positions with different travel length tool holder with heat treated slights.



Lever type tripper module for operator safety.



Steel plates on the back part for machine squaring on the pipe .

### AIR TREATMENT MODULE



Optional module (ATM) provides air treatment capability for KRAIS pneumatic powered split frames.

General technical machine information to enable to make the right choice to suit your application.

For our SFSF clamshells we offer a wide range of pneumatic , electric made 100% in house and hydraulic choose by our engineers or upon customer preference . Such a big range and variety of parameters allow us to select motor to achieve to best and most post suitable cutting speed to machined pipe material and diameter.

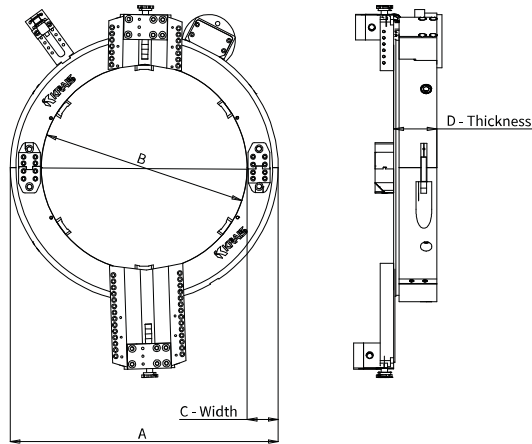

MODEL	PIPE CAPACITY			DIMENSIONS									LOCATOR PADS	GEAR RING RATIO
	UNIT	MIN OD	MAX OD	UNIT	A	B	C	D	1" SLIDE SWING	3" SLIDE SWING	6" SLIDE SWING			
SFSF-0204	NPS	2,000	4,000	[inch]	9,685	4,736	2,500	3,248	12,165	16,165	-	4	4,6:1	
	Metric	60,32	127,00	[mm]	246,00	120,30	63,50	82,50	309,00	410,60	-			
SFSF-0256	NPS	2,500	6,000	[inch]	11,831	6,858	2,500	3,248	14,339	18,339	-	4	5,7:1	
	Metric	73,02	168,27	[mm]	300,50	174,20	63,50	82,50	364,20	465,80	-			
SFSF-0358	NPS	3,500	8,000	[inch]	13,819	8,846	2,500	3,248	16,339	20,339	26,339	4	6,7:1	
	Metric	101,60	219,07	[mm]	351,00	224,70	63,50	82,50	415,00	516,60	669,00			
SFSF-0410	NPS	4,500	10,000	[inch]	16,220	11,236	2,500	3,248	18,756	22,756	28,756	4	7,8:1	
	Metric	127,00	273,05	[mm]	412,00	285,40	63,50	82,50	476,40	578,00	730,40			
SFSF-0612	NPS	6,000	12,000	[inch]	18,150	13,236	2,500	3,248	20,843	24,843	30,843	4	8,9:1	
	Metric	168,27	323,85	[mm]	461,00	336,20	63,50	82,50	529,40	631,00	783,40			
SFSF-0814	NPS	8,000	14,000	[inch]	19,488	14,484	2,500	3,248	22,063	26,063	32,063	6	9,5:1	
	Metric	219,07	355,60	[mm]	495,00	367,90	63,50	82,50	560,40	662,00	814,40			
SFSF-1016	NPS	10,000	16,000	[inch]	21,457	16,484	2,500	3,287	24,102	28,102	34,102	6	10,6:1	
	Metric	273,05	406,40	[mm]	545,00	418,70	63,50	83,50	612,20	713,80	866,20			
SFSF-1218	NPS	12,000	18,000	[inch]	23,504	18,484	2,500	3,287	26,224	30,224	36,224	6	11,6:1	
	Metric	323,85	457,20	[mm]	597,00	469,50	63,50	83,50	666,10	767,70	920,10			
SFSF-1420	NPS	14,000	20,000	[inch]	25,472	20,848	2,500	3,287	28,150	32,150	38,150	6	12,6:1	
	Metric	355,60	508,00	[mm]	647,00	520,30	63,50	83,50	715,00	816,60	969,00			
SFSF-1624	NPS	16,000	24,000	[inch]	29,488	24,406	2,500	3,287	32,268	36,268	42,268	10	14,6:1	
	Metric	406,40	609,60	[mm]	749,00	619,90	63,50	83,50	819,60	921,20	1073,60			
SFSF-2028	NPS	20,000	28,000	[inch]	33,900	28,750	2,757	4,476	36,516	40,516	46,516	10	16,9:1	
	Metric	508,00	711,20	[mm]	861,10	730,30	65,40	113,70	927,50	1029,10	1181,50			
SFSF-2432	NPS	24,000	32,000	[inch]	38,150	33,000	2,757	4,476	40,787	44,787	50,787	10	19:1	
	Metric	609,60	812,80	[mm]	969,00	838,20	65,40	113,70	1036,00	1137,60	1290,00			
SFSF-2836	NPS	28,000	36,000	[inch]	42,150	37,000	2,757	4,476	44,913	48,913	54,913	10	21:1	
	Metric	711,20	914,40	[mm]	1070,60	939,80	65,40	113,70	1140,80	1242,40	1394,80			
SFSF-3442	NPS	34,000	42,000	[inch]	48,150	43,000	2,757	4,476	50,906	54,906	60,906	10	24,2:1	
	Metric	863,60	1066,80	[mm]	1223,00	1092,20	65,40	113,70	1293,00	1394,60	1547,00			
SFSF-4048	NPS	40,000	48,000	[inch]	54,402	49,525	2,757	4,476	57,276	61,276	67,276	12	27,3:1	
	Metric	1016,00	1219,20	[mm]	1381,80	1251,00	65,40	113,70	1454,80	1556,40	1708,80			