

3/8" through 24" GripTight MAX[®] Seal and Gripper Replacement Procedures

Thank you for choosing to use a GripTight MAX (GTMAX[®]) Test Plug. Please refer to these instructions when replacing Seals or Gripper Assemblies on GripTight MAX Test Plugs.

Proper maintenance of your GripTight MAX Test Plugs should always include lubrication of the shaft threads where the Hex Nut(s) is/are installed and both sides of the Hardened Washer(s) with antiseize, as well as lubrication of the tapered surface of the cone with an appropriate lubricant such as Molykote[®] DX paste. The tapered surface should have a light coating lubrication on it, wipe off any excess and ensure the Seal, Gripper Teeth, and the inside of the unit under test are not exposed to any lubricant. Lubrication and inspection should be performed prior to each usage. GripTight MAX Test Plugs should be stored in an area out of direct exposure to sun or ultraviolet (UV) light. Excessive heat or UV light exposure will damage and prematurely degrade the Seal(s).

Type 1 Plug Service Procedures

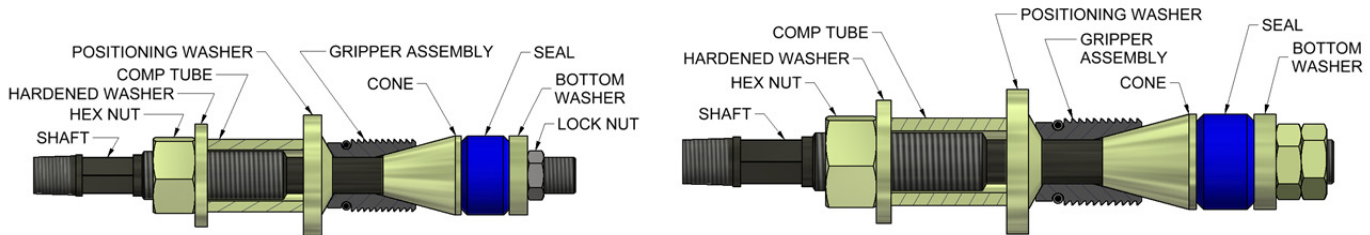

Figure 1: Type 1A/B (left) and Type 1C (right) GripTight MAX Test Plugs

Seal Replacement

1. Remove Lock Nut or Jam Nuts.
2. Remove Bottom Washer.
3. Remove old Seal.
4. Place new Seal on GTMAX Plug.
5. Reinstall the Bottom Washer.
6. Thread the Lock Nut or Jam Nuts back on the Shaft. Jam Nuts on type 1C GTMAX Test Plugs are secured by tightening the Jam Nuts against each other.

Notes:

- Type 1A GTMAX Lock Nuts are round (no flats). Use pliers or a pipe wrench to grip and remove.
- Type 1B GTMAX Lock Nuts have hex flats. An appropriately sized wrench can be used to remove the Lock Nut.
- Type 1C GTMAX Jam Nuts: remove by unjamming (loosening the bottom Jam Nut), then removing both Jam Nuts.

Gripper Assembly Replacement

1. Remove Lock Nut or Jam Nuts.
2. Remove Bottom Washer.
3. Remove Seal.
4. Remove Cone.
5. Remove old Gripper Assembly.
6. Place new Gripper Assembly on GTMAX Test Plug.
7. Lubricate the cone with an appropriate lubricant such as Molykote[®] DX paste.
8. Reinstall the Cone.
9. Reinstall the Seal.
10. Reinstall the Bottom Washer.
11. Thread the Lock Nut or Jam Nuts back on the Shaft. Jam Nuts on type 1C GTMAX Test Plugs are secured by tightening the Jam Nuts against each other.

Notes:

- Type 1A GTMAX Lock Nut is round (no flats). Use pliers or a pipe wrench to grip and remove.
- Type 1B GTMAX Lock Nut has hex flats. An appropriately sized wrench can be used to remove the Lock Nut.
- Type 1C GTMAX Jam Nuts: remove by unjamming (loosening the bottom Jam Nut), then removing both Jam Nuts.
- It is suggested to hand tighten the Hex Nut so the Grippers are against the Cone. This helps maintain tension in the Retaining Spring and prevents Gripper Segments from separating from the GTMAX Test Plug and Gripper Assembly.
- Take care and make sure the tapered surface of the cone is not scratched, marred, or otherwise damaged.

Questions? Contact EST Group Customer Service at any of the following locations.

**CURTISS -
WRIGHT**

EST Group

www.cw-estgroup.com

North, Central & South America

EST Group Corporate Office
2701 Township Line Road
Hatfield, PA 19440-1770 USA

P: +1.215.721.1100

+1.800.355.7044

F: +1.215.721.1101

est-info@curtisswright.com

Europe / Middle East / Africa

EST Group B.V.

Hoor 312a
2404 HL Alphen aan den Rijn
The Netherlands

P: +31.172.418841

F: +31.172.418849

est-emea@curtisswright.com

China

P +86.400.636.5077

est-china@curtisswright.com

Singapore

P +65.3158.5052

est-asia@curtisswright.com

Type 2 Plug Service Procedures

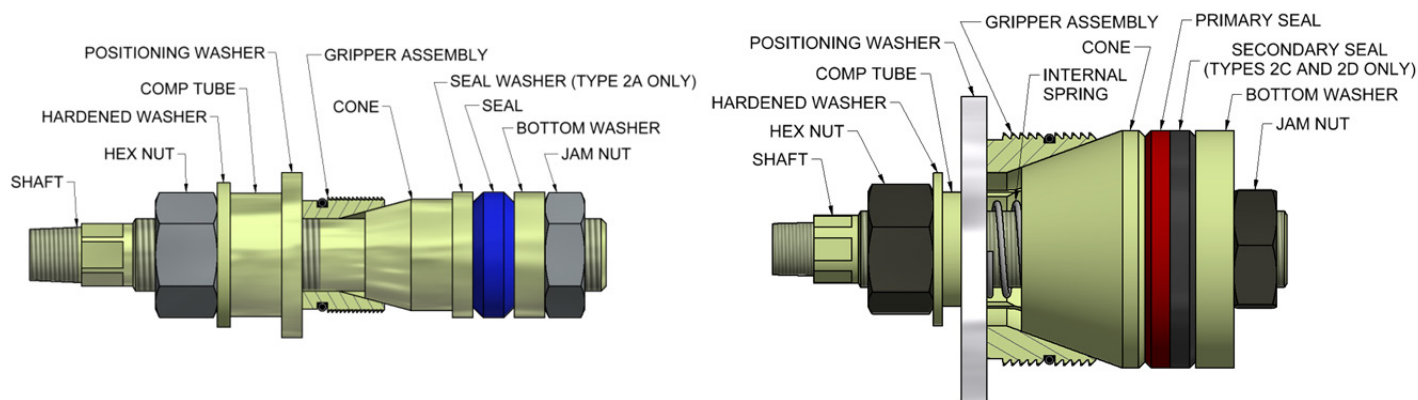

Figure 2: Type 2A/B (left) and Type 2C/D (right) GripTight MAX Test Plugs

Seal Replacement

1. Remove Jam Nut.
2. Remove Bottom Washer.
3. Remove old Secondary Seal (if Type 2C or 2D).
4. Remove old Primary Seal.
5. Place the new Primary Seal on the GTMAX Test Plug. The chamfered edge should face the Cone.
6. Types 2C and 2D Only: Place the new Secondary Seal on the GTMAX Test Plug. The chamfered edge should face the Bottom Washer.
7. Reinstall the Bottom Washer.
8. Reinstall the Jam Nut. Tighten it against the Bottom Washer to secure in place.

Notes:

- The Bottom Washer threads on to the Shaft. Remove by unthreading the Bottom Washer from the Shaft.
- Type 2A GTMAX Test Plugs have the Seal Washer installed between the Seal and the Cone. Type 2B Plugs do not.
- Type 2C and 2D GTMAX Plugs have two (2) Seals, a Primary Seal and a Secondary Seal. The Seals must be placed on the GTMAX Plug in the correct configuration: Secondary Seal against the Bottom Washer, Primary Seal against the Cone. The chamfered edges should face away from each other, towards the Bottom Washer and Cone respectively. See Figure 2 for reference.

Gripper Assembly Replacement

1. Remove Hex Nut.
2. Remove Hardened Washer.
3. Remove Comp Tube.
4. Remove Positioning Washer.
5. Type 2D Plugs: remove the Internal Spring.
6. Remove old Gripper Assembly.
7. Lubricate the cone with an appropriate lubricant such as Molykote® DX paste.
8. Place new Gripper Assembly on GTMAX Test Plug.
9. Type 2D Plugs: Reinstall the Compression Spring.
10. Reinstall the Positioning Washer. Markings should be visible and face the Comp Tube (away from the Gripper Assembly).
11. Reinstall the Comp Tube.
12. Reinstall the Hardened Washer.
13. Reinstall the Hex Nut.

Notes:

- GTMAX-5PXXS is not equipped with a Comp Tube.
- Care must always be taken to not scratch, mar, or otherwise damage the tapered surface of the Cone.
- It is suggested to hand tighten the Hex Nut so the Grippers travel slightly up the Cone. This helps maintain tension in the Retaining Spring and prevents Gripper Segments from separating from the GTMAX Test Plug and Gripper Assembly.

Questions? Contact EST Group Customer Service at any of the following locations.

**CURTISS -
WRIGHT**

EST Group

www.cw-estgroup.com

North, Central & South America

EST Group Corporate Office
2701 Township Line Road
Hatfield, PA 19440-1770 USA

P: +1.215.721.1100

+1.800.355.7044

F: +1.215.721.1101

est-info@curtisswright.com

Europe / Middle East / Africa

EST Group B.V.
Hoor 312a
2404 HL Alphen aan den Rijn
The Netherlands

P: +31.172.418841

F: +31.172.418849

est-emea@curtisswright.com

China

P +86.400.636.5077

est-china@curtisswright.com

Singapore

P +65.3158.5052

est-asia@curtisswright.com

Type 3 Plug Service Procedures

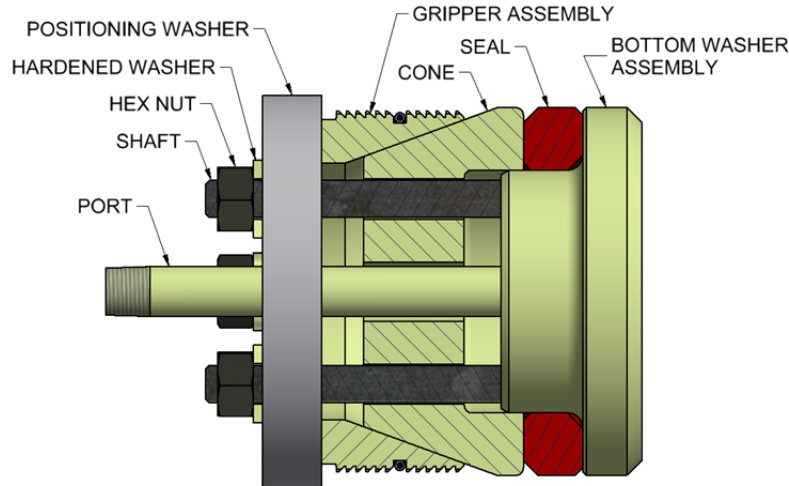

Figure 3: Type 3 GripTight MAX Test Plugs

Seal Replacement

1. Remove Hex Nuts and Hardened Washers.
2. Remove Positioning Washer.
3. Remove Gripper Assembly.
4. Remove Cone.
5. Remove old Seal.
6. Place new Seal on Bottom Washer Assembly. The large chamfer on the Seal should face the Cone.
7. Reinstall the Cone.
8. Lubricate the cone with an appropriate lubricant such as Molykote® DX paste.
9. Reinstall the Gripper Assembly.
10. Reinstall the Positioning Washer. Markings should face the Hex Nuts (away from the Gripper Assembly).
11. Reinstall the Hardened Washers.
12. Reinstall the Hex Nuts.

- Shafts are part of the Bottom Washer Assembly. They should not be removed. If the shafts are loose, they may be reinstalled so they bottom out in the Bottom Washer Assembly and secured with a permanent thread locker such as Titan Cyberbond T-1550 or Loctite 262.
- The Seal has asymmetrical chamfers. Place the Seal on the Far Support with the large chamfer facing the Cone. See Figure 3 for reference.
- Take care and make sure the tapered surface of the cone is not scratched, marred, or otherwise damaged. It is suggested to hand tighten the Hex Nuts so the Grippers travel slightly up the Cone. This helps maintain tension in the Retaining Spring and prevents Gripper Segments from separating from the GTMAX Test Plug and Gripper Assembly.

Gripper Assembly Replacement

1. Remove Hex Nuts and Hardened Washers.
2. Remove Positioning Washer.
3. Remove the old Gripper Assembly.
4. Lubricate the cone with an appropriate lubricant such as Molykote® DX paste.
5. Place new Gripper Assembly on the GTMAX Test Plug.
6. Reinstall the Positioning Washer. Markings should be visible and face the Hex Nuts (away from the Gripper Assembly).
7. Reinstall the Hardened Washers.
8. Reinstall the Hex Nuts.

- If Gripper Segments fall off of Gripper Assembly, the Gripper Segments can be reinstalled in the Gripper Assembly by positioning the Retaining Spring over the Shaft and sliding the Gripper Segments on individually. Slide the Retaining Spring into the spring grooves on each Gripper Segment. Using a screwdriver or similar tool to help pry the Retaining Spring into place is useful. Care must always be taken to not scratch, mar, or otherwise damage the tapered surface of the Cone.

Questions? Contact EST Group Customer Service at any of the following locations.

**CURTISS -
WRIGHT**

EST Group

www.cw-estgroup.com

North, Central & South America

EST Group Corporate Office
2701 Township Line Road
Hatfield, PA 19440-1770 USA

P: +1.215.721.1100

+1.800.355.7044

F: +1.215.721.1101

est-info@curtisswright.com

Europe / Middle East / Africa

EST Group B.V.
Hoor 312a
2404 HL Alphen aan den Rijn
The Netherlands

P: +31.172.418841

F: +31.172.418849

est-emea@curtisswright.com

China

P +86.400.636.5077

est-china@curtisswright.com

Singapore

P +65.3158.5052

est-asia@curtisswright.com

Type 4 Plug Service Procedures

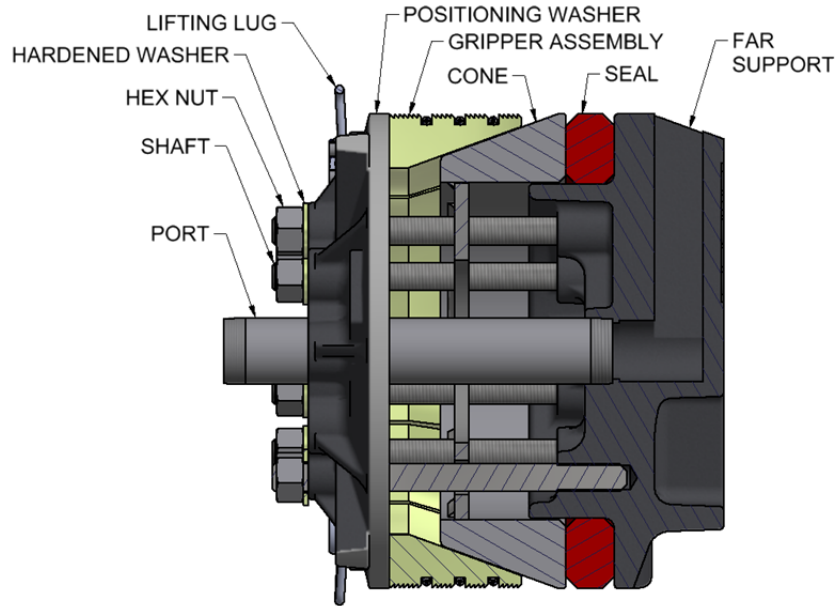

Figure 4: Type 4 GripTight MAX Test Plugs

Seal Replacement

1. Remove Hex Nuts and Hardened Washers.
2. Remove Positioning Washer.
3. Remove Gripper Assembly.
4. Remove Cone.
5. Remove old Seal.
6. Place new Seal on Bottom Washer Assembly.
7. Reinstall the Cone.
8. Lubricate the cone with an appropriate lubricant such as Molykote® DX paste.
9. Reinstall the Gripper Assembly.
10. Reinstall the Positioning Washer.
11. Reinstall the Hardened Washers.
12. Reinstall the Hex Nuts.

- Shafts are part of the Far Support. They should not be removed. If the shafts are loose, they may be reinstalled so they bottom out in the Far Support and secured with a permanent thread locker such as Titan Cyberbond T-1550 or Loctite 262.
- It is suggested to hand tighten the Hex Nuts so the Grippers travel slightly up the Cone. This helps maintain tension in the Retaining Spring and prevents Gripper Segments from separating from the GTMAX Test Plug and Gripper Assembly.
- Take care and make sure the tapered surface of the cone is not scratched, marred, or otherwise damaged.

Gripper Assembly Replacement

1. Remove Hex Nuts and Hardened Washers.
2. Remove Positioning Washer.
3. Remove the old Gripper Assembly.
4. Lubricate the cone with an appropriate lubricant such as Molykote® DX paste.
5. Place new Gripper Assembly on the GTMAX Test Plug.
6. Reinstall the Positioning Washer.
7. Reinstall the Hardened Washers.
8. Reinstall the Hex Nuts.

- If Gripper Segments fall off of Gripper Assembly, the Gripper Segments can be reinstalled in the Gripper Assembly by positioning the Retaining Spring over the Shaft and sliding the Gripper Segments on individually. Slide the Retaining Spring into the spring grooves on each Gripper Segment. Using a screwdriver or similar tool to help pry the Retaining Spring into place is useful. Care must always be taken to not scratch, mar, or otherwise damage the tapered surface of the Cone.

Questions? Contact EST Group Customer Service at any of the following locations.

**CURTISS -
WRIGHT**

EST Group

www.cw-estgroup.com

North, Central & South America

EST Group Corporate Office
2701 Township Line Road
Hatfield, PA 19440-1770 USA

P: +1.215.721.1100

+1.800.355.7044

F: +1.215.721.1101

est-info@curtisswright.com

Europe / Middle East / Africa

EST Group B.V.
Hoor 312a
2404 HL Alphen aan den Rijn
The Netherlands

P: +31.172.418841

F: +31.172.418849

est-emea@curtisswright.com

China

P +86.400.636.5077

est-china@curtisswright.com

Singapore

P +65.3158.5052

est-asia@curtisswright.com

Table 1: Replacement Parts and Accessories for Standard NPS Size GripTight MAX Test Plugs

GTMAX Plug Part Number	Plug Type	Replacement Seal	Replacement Gripper Assembly (Includes Retaining Spring)	Replacement Spring
GTMAX-038P40	1A	GTMAX-038P40-URS	GTMAX-038P40-GR	GTMAX-038P40-SPR
GTMAX-050P80	1A	GTMAX-050P80-URS	GTMAX-050P80-GR	GTMAX-050P80-SPR
GTMAX-050P40	1A	GTMAX-050P40-URS	GTMAX-050P40-GR	GTMAX-050P40-SPR
GTMAX-075P160	1B	GTMAX-075P160-URS	GTMAX-075P160-GR	GTMAX-075P160-SPR
GTMAX-1PXXS	1B	GTMAX-1PXXS-URS	GTMAX-1PXXS-GR	GTMAX-1PXXS-SPR
GTMAX-050P10	1B	GTMAX-050P10-URS	GTMAX-050P10-GR	GTMAX-050P10-SPR
GTMAX-075P80	1B	GTMAX-075P80-URS	GTMAX-075P80-GR	GTMAX-075P80-SPR
GTMAX-075P40	1C	GTMAX-075P40-URS	GTMAX-075P40-GR	GTMAX-075P40-SPR
GTMAX-075P10	1C	GTMAX-075P10-URS	GTMAX-075P10-GR	GTMAX-075P10-SPR
GTMAX-1P160	1C	GTMAX-1P160-URS	GTMAX-1P160-GR	GTMAX-1P160-SPR
GTMAX-1P80	2A	GTMAX-1P80-URS	GTMAX-1P80-GR	GTMAX-1P80-SPR
GTMAX-1P40	2A	GTMAX-1P40-URS	GTMAX-1P40-GR	GTMAX-1P40-SPR
GTMAX-1P10	2A	GTMAX-1P10-URS	GTMAX-1P10-GR	GTMAX-1P10-SPR
GTMAX-15PXXS	2A	GTMAX-15PXXS-URS	GTMAX-15PXXS-GR	GTMAX-15PXXS-SPR
GTMAX-1P5	2A	GTMAX-1P5-URS	GTMAX-1P5-GR	GTMAX-1P5-SPR
GTMAX-125P160	2A	GTMAX-125P160-URS	GTMAX-125P160-GR	GTMAX-125P160-SPR
GTMAX-125P80	2A	GTMAX-125P80-URS	GTMAX-125P80-GR	GTMAX-125P80-SPR
GTMAX-125P40	2A	GTMAX-125P40-URS	GTMAX-125P40-GR	GTMAX-125P40-SPR
GTMAX-15P160	2A	GTMAX-15P160-URS	GTMAX-15P160-GR	GTMAX-15P160-SPR
GTMAX-125P10	2A	GTMAX-125P10-URS	GTMAX-125P10-GR	GTMAX-125P10-SPR
GTMAX-125P5	2A	GTMAX-125P5-URS	GTMAX-125P5-GR	GTMAX-125P5-SPR
GTMAX-15P80	2A	GTMAX-15P80-URS	GTMAX-15P80-GR	GTMAX-15P80-SPR
GTMAX-2PXXS	2A	GTMAX-2PXXS-URS	GTMAX-2PXXS-GR	GTMAX-2PXXS-SPR
GTMAX-15P40	2A	GTMAX-15P40-URS	GTMAX-15P40-GR	GTMAX-15P40-SPR
GTMAX-15P10	2A	GTMAX-15P10-URS	GTMAX-15P10-GR	GTMAX-15P10-SPR
GTMAX-2P160	2A	GTMAX-2P160-URS	GTMAX-2P160-GR	GTMAX-2P160-SPR
GTMAX-15P5	2A	GTMAX-15P5-URS	GTMAX-15P5-GR	GTMAX-15P5-SPR
GTMAX-25PXXS	2A	GTMAX-25PXXS-URS	GTMAX-25PXXS-GR	GTMAX-25PXXS-SPR
GTMAX-2P80	2A	GTMAX-2P80-URS	GTMAX-2P80-GR	GTMAX-2P80-SPR
GTMAX-2P40	2A	GTMAX-2P40-URS	GTMAX-2P40-GR	GTMAX-2P40-SPR
GTMAX-2P10	2A	GTMAX-2P10-URS	GTMAX-2P10-GR	GTMAX-2P10-SPR
GTMAX-25P160	2A	GTMAX-25P160-URS	GTMAX-25P160-GR	GTMAX-25P160-SPR
GTMAX-2P5	2A	GTMAX-2P5-URS	GTMAX-2P5-GR	GTMAX-2P5-SPR
GTMAX-25P80	2A	GTMAX-25P80-URS	GTMAX-25P80-GR	GTMAX-25P80-SPR
GTMAX-3PXXS	2A	GTMAX-3PXXS-URS	GTMAX-3PXXS-GR	GTMAX-3PXXS-SPR
GTMAX-25P40	2B	GTMAX-25P40-URS	GTMAX-25P40-GR	GTMAX-25P40-SPR

Questions? Contact EST Group Customer Service at any of the following locations.

**CURTISS-
WRIGHT**

EST Group

www.cw-estgroup.com

North, Central & South America

EST Group Corporate Office
2701 Township Line Road
Hatfield, PA 19440-1770 USA

P: +1.215.721.1100

+1.800.355.7044

F: +1.215.721.1101

est-info@curtisswright.com

Europe / Middle East / Africa

EST Group B.V.
Hoor 312a
2404 HL Alphen aan den Rijn
The Netherlands

P: +31.172.418841

F: +31.172.418849

est-emea@curtisswright.com

China

P +86.400.636.5077

est-china@curtisswright.com

Singapore

P +65.3158.5052

est-asia@curtisswright.com

GTMAX Plug Part Number	Plug Type	Replacement Seal	Replacement Gripper Assembly (Includes Retaining Spring)	Replacement Spring
GTMAX-25P10	2B	GTMAX-25P10-URS	GTMAX-25P10-GR	GTMAX-25P10-SPR
GTMAX-3P160	2B	GTMAX-3P160-URS	GTMAX-3P160-GR	GTMAX-3P160-SPR
GTMAX-25P5	2B	GTMAX-25P5-URS	GTMAX-25P5-GR	GTMAX-25P5-SPR
GTMAX-35PXXS	2B	GTMAX-35PXXS-URS	GTMAX-35PXXS-GR	GTMAX-35PXXS-SPR
GTMAX-3P80	2B	GTMAX-3P80-URS	GTMAX-3P80-GR	GTMAX-3P80-SPR
GTMAX-3P40	2B	GTMAX-3P40-URS	GTMAX-3P40-GR	GTMAX-3P40-SPR
GTMAX-4PXXS	2B	GTMAX-4PXXS-URS	GTMAX-4PXXS-GR	GTMAX-4PXXS-SPR
GTMAX-3P10	2B	GTMAX-3P10-URS	GTMAX-3P10-GR	GTMAX-3P10-SPR
GTMAX-3P5	2B	GTMAX-3P5-URS	GTMAX-3P5-GR	GTMAX-3P5-SPR
GTMAX-35P80	2B	GTMAX-35P80-URS	GTMAX-35P80-GR	GTMAX-35P80-SPR
GTMAX-4P160	2B	GTMAX-4P160-URS	GTMAX-4P160-GR	GTMAX-4P160-SPR
GTMAX-35P40	2B	GTMAX-35P40-URS	GTMAX-35P40-GR	GTMAX-35P40-SPR
GTMAX-4P120	2B	GTMAX-4P120-URS	GTMAX-4P120-GR	GTMAX-4P120-SPR
GTMAX-35P10	2B	GTMAX-35P10-URS	GTMAX-35P10-GR	GTMAX-35P10-SPR
GTMAX-35P5	2B	GTMAX-35P5-URS	GTMAX-35P5-GR	GTMAX-35P5-SPR
GTMAX-4P80	2B	GTMAX-4P80-URS	GTMAX-4P80-GR	GTMAX-4P80-SPR
GTMAX-4P40	2B	GTMAX-4P40-URS	GTMAX-4P40-GR	GTMAX-4P40-SPR
GTMAX-5PXXS	2B	GTMAX-5PXXS-URS	GTMAX-5PXXS-GR	GTMAX-5PXXS-SPR
GTMAX-4P10	2B	GTMAX-4P10-URS	GTMAX-4P10-GR	GTMAX-4P10-SPR
GTMAX-4P5	2C	GTMAX-4P5-NRS	GTMAX-4P5-GR	GTMAX-4P5-SPR
GTMAX-5P160	2C	GTMAX-5P160-NRS	GTMAX-5P160-GR	GTMAX-5P160-SPR
GTMAX-5P120	2C	GTMAX-5P120-NRS	GTMAX-5P120-GR	GTMAX-5P120-SPR
GTMAX-5P80	2D	GTMAX-5P80-NRS	GTMAX-5P80-GR	GTMAX-5P80-SPR
GTMAX-6PXXS	3	GTMAX-6PXXS-URS	GTMAX-6PXXS-GR	GTMAX-6PXXS-SPR
GTMAX-5P40	3	GTMAX-5P40-URS	GTMAX-5P40-GR	GTMAX-5P40-SPR
GTMAX-6P160	3	GTMAX-6P160-URS	GTMAX-6P160-GR	GTMAX-6P160-SPR
GTMAX-5P10	3	GTMAX-5P10-URS	GTMAX-5P10-GR	GTMAX-5P10-SPR
GTMAX-5P5	3	GTMAX-5P5-URS	GTMAX-5P5-GR	GTMAX-5P5-SPR
GTMAX-6P120	3	GTMAX-6P120-URS	GTMAX-6P120-GR	GTMAX-6P120-SPR
GTMAX-6P80	3	GTMAX-6P80-URS	GTMAX-6P80-GR	GTMAX-6P80-SPR
GTMAX-6P40	3	GTMAX-6P40-URS	GTMAX-6P40-GR	GTMAX-6P40-SPR
GTMAX-6P10	3	GTMAX-6P10-URS	GTMAX-6P10-GR	GTMAX-6P10-SPR
GTMAX-6P5	3	GTMAX-6P5-URS	GTMAX-6P5-GR	GTMAX-6P5-SPR
GTMAX-8P160	3	GTMAX-8P160-URS	GTMAX-8P160-GR	GTMAX-8P160-SPR
GTMAX-8PXXS	3	GTMAX-8PXXS-URS	GTMAX-8PXXS-GR	GTMAX-8PXXS-SPR
GTMAX-8P140	3	GTMAX-8P140-URS	GTMAX-8P140-GR	GTMAX-8P140-SPR
GTMAX-8P120	3	GTMAX-8P120-URS	GTMAX-8P120-GR	GTMAX-8P120-SPR

Questions? Contact EST Group Customer Service at any of the following locations.



EST Group

www.cw-estgroup.com

North, Central & South America

EST Group Corporate Office
2701 Township Line Road
Hatfield, PA 19440-1770 USA

P: +1.215.721.1100

+1.800.355.7044

F: +1.215.721.1101

est-info@curtisswright.com

Europe / Middle East / Africa

EST Group B.V.
Hoor 312a
2404 HL Alphen aan den Rijn
The Netherlands

P: +31.172.418841

F: +31.172.418849

est-emea@curtisswright.com

China

P +86.400.636.5077

est-china@curtisswright.com

Singapore

P +65.3158.5052

est-asia@curtisswright.com

GTMAX Plug Part Number	Plug Type	Replacement Seal	Replacement Gripper Assembly (Includes Retaining Spring)	Replacement Spring
GTMAX-8P100	3	GTMAX-8P100-URS	GTMAX-8P100-GR	GTMAX-8P100-SPR
GTMAX-8P80	3	GTMAX-8P80-URS	GTMAX-8P80-GR	GTMAX-8P80-SPR
GTMAX-8P60	3	GTMAX-8P60-URS	GTMAX-8P60-GR	GTMAX-8P60-SPR
GTMAX-8P40	3	GTMAX-8P40-URS	GTMAX-8P40-GR	GTMAX-8P40-SPR
GTMAX-8P30	3	GTMAX-8P30-URS	GTMAX-8P30-GR	GTMAX-8P30-SPR
GTMAX-8P20	3	GTMAX-8P20-URS	GTMAX-8P20-GR	GTMAX-8P20-SPR
GTMAX-8P10	3	GTMAX-8P10-URS	GTMAX-8P10-GR	GTMAX-8P10-SPR
GTMAX-8P5	3	GTMAX-8P5-URS	GTMAX-8P5-GR	GTMAX-8P5-SPR
GTMAX-10P160	3	GTMAX-10P160-URS	GTMAX-10P160-GR	GTMAX-10P160-SPR
GTMAX-10P140	3	GTMAX-10P140-URS	GTMAX-10P140-GR	GTMAX-10P140-SPR
GTMAX-10P120	3	GTMAX-10P120-URS	GTMAX-10P120-GR	GTMAX-10P120-SPR
GTMAX-10P100	4	GTMAX-10P100-RS	GTMAX-10P100-GR	GTMAX-10P100-SPR
GTMAX-10P80	4	GTMAX-10P80-RS	GTMAX-10P80-GR	GTMAX-10P80-SPR
GTMAX-10P60	4	GTMAX-10P60-RS	GTMAX-10P60-GR	GTMAX-10P60-SPR
GTMAX-10P40	4	GTMAX-10P40-RS	GTMAX-10P40-GR	GTMAX-10P40-SPR
GTMAX-12P160	4	GTMAX-12P160-RS	GTMAX-12P160-GR	GTMAX-12P160-SPR
GTMAX-10P30	4	GTMAX-10P30-RS	GTMAX-10P30-GR	GTMAX-10P30-SPR
GTMAX-10P20	4	GTMAX-10P20-RS	GTMAX-10P20-GR	GTMAX-10P20-SPR
GTMAX-10P10	4	GTMAX-10P10-RS	GTMAX-10P10-GR	GTMAX-10P10-SPR
GTMAX-10P5	4	GTMAX-10P5-RS	GTMAX-10P5-GR	GTMAX-10P5-SPR
GTMAX-12P140	4	GTMAX-12P140-RS	GTMAX-12P140-GR	GTMAX-12P140-SPR
GTMAX-12P120	4	GTMAX-12P120-RS	GTMAX-12P120-GR	GTMAX-12P120-SPR
GTMAX-12P100	4	GTMAX-12P100-RS	GTMAX-12P100-GR	GTMAX-12P100-SPR
GTMAX-14P160	4	GTMAX-14P160-RS	GTMAX-14P160-GR	GTMAX-14P160-SPR
GTMAX-12P80	4	GTMAX-12P80-RS	GTMAX-12P80-GR	GTMAX-12P80-SPR
GTMAX-14P140	4	GTMAX-14P140-RS	GTMAX-14P140-GR	GTMAX-14P140-SPR
GTMAX-12P60	4	GTMAX-12P60-RS	GTMAX-12P60-GR	GTMAX-12P60-SPR
GTMAX-12PXS	4	GTMAX-12PXS-RS	GTMAX-12PXS-GR	GTMAX-12PXS-SPR
GTMAX-14P120	4	GTMAX-14P120-RS	GTMAX-14P120-GR	GTMAX-14P120-SPR
GTMAX-12P40	4	GTMAX-12P40-RS	GTMAX-12P40-GR	GTMAX-12P40-SPR
GTMAX-12P30	4	GTMAX-12P30-RS	GTMAX-12P30-GR	GTMAX-12P30-SPR
GTMAX-14P100	4	GTMAX-14P100-RS	GTMAX-14P100-GR	GTMAX-14P100-SPR
GTMAX-12P20	4	GTMAX-12P20-RS	GTMAX-12P20-GR	GTMAX-12P20-SPR
GTMAX-12P10	4	GTMAX-12P10-RS	GTMAX-12P10-GR	GTMAX-12P10-SPR
GTMAX-14P80	4	GTMAX-14P80-RS	GTMAX-14P80-GR	GTMAX-14P80-SPR
GTMAX-14P60	4	GTMAX-14P60-RS	GTMAX-14P60-GR	GTMAX-14P60-SPR
GTMAX-16P160	4	GTMAX-16P160-RS	GTMAX-16P160-GR	GTMAX-16P160-SPR

Questions? Contact EST Group Customer Service at any of the following locations.

**CURTISS -
WRIGHT**

EST Group

www.cw-estgroup.com

North, Central & South America

EST Group Corporate Office
2701 Township Line Road
Hatfield, PA 19440-1770 USA

P: +1.215.721.1100

+1.800.355.7044

F: +1.215.721.1101

est-info@curtisswright.com

Europe / Middle East / Africa

EST Group B.V.
Hoorn 312a
2404 HL Alphen aan den Rijn
The Netherlands

P: +31.172.418841

F: +31.172.418849

est-emea@curtisswright.com

China

P +86.400.636.5077

est-china@curtisswright.com

Singapore

P +65.3158.5052

est-asia@curtisswright.com

GTMAX Plug Part Number	Plug Type	Replacement Seal	Replacement Gripper Assembly (Includes Retaining Spring)	Replacement Spring
GTMAX-14PXS	4	GTMAX-14PXS-RS	GTMAX-14PXS-GR	GTMAX-14PXS-SPR
GTMAX-14P40	4	GTMAX-14P40-RS	GTMAX-14P40-GR	GTMAX-14P40-SPR
GTMAX16P140	4	GTMAX16P140-RS	GTMAX16P140-GR	GTMAX16P140-SPR
GTMAX-14P30	4	GTMAX-14P30-RS	GTMAX-14P30-GR	GTMAX-14P30-SPR
GTMAX-14P20	4	GTMAX-14P20-RS	GTMAX-14P20-GR	GTMAX-14P20-SPR
GTMAX-14P10	4	GTMAX-14P10-RS	GTMAX-14P10-GR	GTMAX-14P10-SPR
GTMAX-16P120	4	GTMAX-16P120-RS	GTMAX-16P120-GR	GTMAX-16P120-SPR
GTMAX-14P10S	4	GTMAX-14P10S-RS	GTMAX-14P10S-GR	GTMAX-14P10S-SPR
GTMAX-14P5	4	GTMAX-14P5-RS	GTMAX-14P5-GR	GTMAX-14P5-SPR
GTMAX-16P100	4	GTMAX-16P100-RS	GTMAX-16P100-GR	GTMAX-16P100-SPR
GTMAX-16P80	4	GTMAX-16P80-RS	GTMAX-16P80-GR	GTMAX-16P80-SPR
GTMAX-180160	4	GTMAX-180160-RS	GTMAX-180160-GR	GTMAX-180160-SPR
GTMAX-16P60	4	GTMAX-16P60-RS	GTMAX-16P60-GR	GTMAX-16P60-SPR
GTMAX-18P140	4	GTMAX-18P140-RS	GTMAX-18P140-GR	GTMAX-18P140-SPR
GTMAX-16PXS	4	GTMAX-16PXS-RS	GTMAX-16PXS-GR	GTMAX-16PXS-SPR
GTMAX-16PSTD	4	GTMAX-16PSTD-RS	GTMAX-16PSTD-GR	GTMAX-16PSTD-SPR
GTMAX-18P120	4	GTMAX-18P120-RS	GTMAX-18P120-GR	GTMAX-18P120-SPR
GTMAX-16P20	4	GTMAX-16P20-RS	GTMAX-16P20-GR	GTMAX-16P20-SPR
GTMAX-16P10	4	GTMAX-16P10-RS	GTMAX-16P10-GR	GTMAX-16P10-SPR
GTMAX-16P10S	4	GTMAX-16P10S-RS	GTMAX-16P10S-GR	GTMAX-16P10S-SPR
GTMAX-16P5	4	GTMAX-16P5-RS	GTMAX-16P5-GR	GTMAX-16P5-SPR
GTMAX-18P100	4	GTMAX-18P100-RS	GTMAX-18P100-GR	GTMAX-18P100-SPR
GTMAX-20P160	4	GTMAX-20P160-RS	GTMAX-20P160-GR	GTMAX-20P160-SPR
GTMAX-18P80	4	GTMAX-18P80-RS	GTMAX-18P80-GR	GTMAX-18P80-SPR
GTMAX-18P60	4	GTMAX-18P60-RS	GTMAX-18P60-GR	GTMAX-18P60-SPR
GTMAX-20P140	4	GTMAX-20P140-RS	GTMAX-20P140-GR	GTMAX-20P140-SPR
GTMAX-18P40	4	GTMAX-18P40-RS	GTMAX-18P40-GR	GTMAX-18P40-SPR
GTMAX-18PXS	4	GTMAX-18PXS-RS	GTMAX-18PXS-GR	GTMAX-18PXS-SPR
GTMAX-20P120	4	GTMAX-20P120-RS	GTMAX-20P120-GR	GTMAX-20P120-SPR
GTMAX-18P30	4	GTMAX-18P30-RS	GTMAX-18P30-GR	GTMAX-18P30-SPR
GTMAX-18PSTD	4	GTMAX-18PSTD-RS	GTMAX-18PSTD-GR	GTMAX-18PSTD-SPR
GTMAX-18P20	4	GTMAX-18P20-RS	GTMAX-18P20-GR	GTMAX-18P20-SPR
GTMAX-20P100	4	GTMAX-20P100-RS	GTMAX-20P100-GR	GTMAX-20P100-SPR
GTMAX-18P10	4	GTMAX-18P10-RS	GTMAX-18P10-GR	GTMAX-18P10-SPR
GTMAX-18P10S	4	GTMAX-18P10S-RS	GTMAX-18P10S-GR	GTMAX-18P10S-SPR
GTMAX-18P5	4	GTMAX-18P5-RS	GTMAX-18P5-GR	GTMAX-18P5-SPR
GTMAX-22P160	4	GTMAX-22P160-RS	GTMAX-22P160-GR	GTMAX-22P160-SPR

Questions? Contact EST Group Customer Service at any of the following locations.

**CURTISS-
WRIGHT**

EST Group

www.cw-estgroup.com

North, Central & South America

EST Group Corporate Office
2701 Township Line Road
Hatfield, PA 19440-1770 USA

P: +1.215.721.1100

+1.800.355.7044

F: +1.215.721.1101

est-info@curtisswright.com

Europe / Middle East / Africa

EST Group B.V.
Hoorn 312a
2404 HL Alphen aan den Rijn
The Netherlands

P: +31.172.418841

F: +31.172.418849

est-emea@curtisswright.com

China

P +86.400.636.5077

est-china@curtisswright.com

Singapore

P +65.3158.5052

est-asia@curtisswright.com

GTMAX Plug Part Number	Plug Type	Replacement Seal	Replacement Gripper Assembly (Includes Retaining Spring)	Replacement Spring
GTMAX-20P80	4	GTMAX-20P80-RS	GTMAX-20P80-GR	GTMAX-20P80-SPR
GTMAX-22P140	4	GTMAX-22P140-RS	GTMAX-22P140-GR	GTMAX-22P140-SPR
GTMAX-20P60	4	GTMAX-20P60-RS	GTMAX-20P60-GR	GTMAX-20P60-SPR
GTMAX-22P120	4	GTMAX-22P120-RS	GTMAX-22P120-GR	GTMAX-22P120-SPR
GTMAX-20P40	4	GTMAX-20P40-RS	GTMAX-20P40-GR	GTMAX-20P40-SPR
GTMAX-20PXS	4	GTMAX-20PXS-RS	GTMAX-20PXS-GR	GTMAX-20PXS-SPR
GTMAX-20PSTD	4	GTMAX-20PSTD-RS	GTMAX-20PSTD-GR	GTMAX-20PSTD-SPR
GTMAX-22P100	4	GTMAX-22P100-RS	GTMAX-22P100-GR	GTMAX-22P100-SPR
GTMAX-24P160	4	GTMAX-24P160-RS	GTMAX-24P160-GR	GTMAX-24P160-SPR
GTMAX-20P10	4	GTMAX-20P10-RS	GTMAX-20P10-GR	GTMAX-20P10-SPR
GTMAX-20P5	4	GTMAX-20P5-RS	GTMAX-20P5-GR	GTMAX-20P5-SPR
GTMAX-22P80	4	GTMAX-22P80-RS	GTMAX-22P80-GR	GTMAX-22P80-SPR
GTMAX-24P140	4	GTMAX-24P140-RS	GTMAX-24P140-GR	GTMAX-24P140-SPR
GTMAX-22P60	4	GTMAX-22P60-RS	GTMAX-22P60-GR	GTMAX-22P60-SPR
GTMAX-24P120	4	GTMAX-24P120-RS	GTMAX-24P120-GR	GTMAX-24P120-SPR
GTMAX-24P100	4	GTMAX-24P100-RS	GTMAX-24P100-GR	GTMAX-24P100-SPR

Questions? Contact EST Group Customer Service at any of the following locations.

**CURTISS -
WRIGHT**

EST Group

www.cw-estgroup.com

North, Central & South America

EST Group Corporate Office
2701 Township Line Road
Hatfield, PA 19440-1770 USA

P: +1.215.721.1100

+1.800.355.7044

F: +1.215.721.1101

est-info@curtisswright.com

Europe / Middle East / Africa

EST Group B.V.
Hoor 312a
2404 HL Alphen aan den Rijn
The Netherlands

P: +31.172.418841

F: +31.172.418849

est-emea@curtisswright.com

China

P +86.400.636.5077

est-china@curtisswright.cn

Singapore

P +65.3158.5052

est-asia@curtisswright.com