

Inquiry Sheet for Tube Expanders

To:

Fax +

■ Please attach the drawing of the workpiece.

1	Tube Size	OD	X	t
2	Tube Material			
3	Tube Sheet Thickness	T1	T2	
4	Tube Sheet Material			
5	Tube Sheet Hole Dia	H	Tolerance	
6	No. of Tubes to be Expanded			
7	Expansion Length	A1	A2	
8	Length of Tube Projection	E		
9	Hole Pitch & Arrangement	P1	P2	a
		P3	P4	
10	Use of Lubrication Oil	Use	No use	
11	Distance between Expansion	C	F	
12	Flare Angle	0°		
13	Length of Straight Tube Part	S		
14	Curve Radius	R		

Sketch of expanding area

Remarks

■ Dimensions (mm)

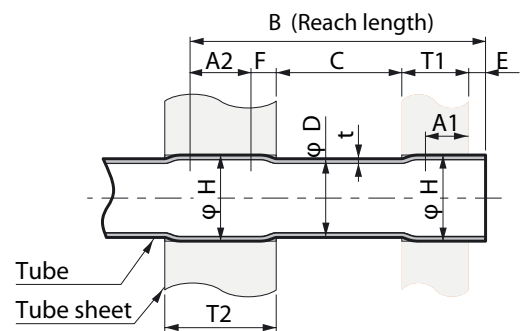
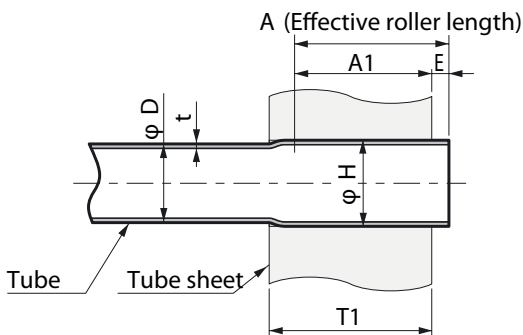
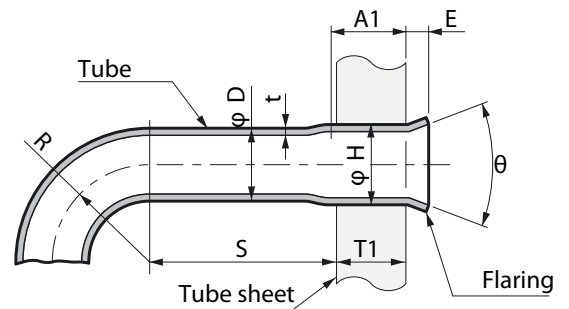
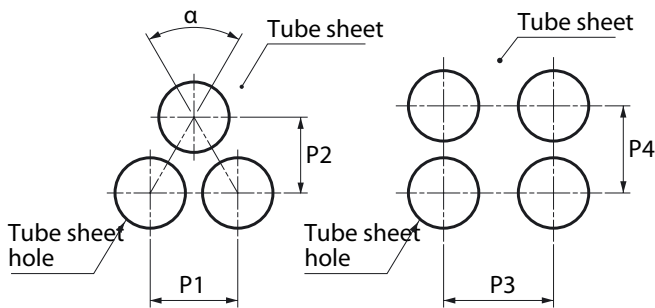

INQ. No.	Date
Company Name	
Name	Title or Position
Address	
Phone	Fax
E-mail Address	



Equipment Group Investments Ltd.

812 Utah Street, South Houston, Texas 77587

Tel. 713-944-2775, Fax 713-944-2891

expander01@aol.com